

Impulse Withstand Voltage as High as 10 kV with 4-kV Dielectric Strength: Ideal for Power Supply Switching

- Creepage distance of 8 mm min. meets VDE C250.
- Dielectric strength of 4,000 VAC min.
- SPST-NO types conform to TV-8 rating.
- DPST-NO types conform to TV-5 rating.
- International 2.54-mm terminal pitch.



RoHS Compliant Refer to pages 16 to 17 for details.



Ordering Information

Contacts		SPST-NO	DPST-NO
Mounting style	Terminals		
General purpose	PCB (straight)	G4W-1112P-US-TV8	G4W-2212P-US-TV5

Note: When ordering, add the rated coil voltage to the model number.
Example: G4W-1112P-US-TV8 12 VDC

Rated coil voltage

Model Number Legend

G4W - - - - VDC
 1 2 3 4 5 6 7 8

- | | | |
|---|--|--|
| <p>1. Contact Form
11: SPST-NO
22: DPST-NO</p> <p>2. Contact Type
1: Single button</p> <p>3. Enclosure Ratings
2: Unsealed</p> | <p>4. Terminals
P: Straight PCB</p> <p>5. Approved Standards
US: UL, CSA certified</p> | <p>6. TV Ratings
TV5: TV-5
TV8: TV-8</p> <p>7. Special Function
None: General-purpose
Z: Full-wave rectifier</p> <p>8. Rated Coil Voltage
12, 24, 100 VDC</p> |
|---|--|--|



Specifications

■ Coil Ratings

Single-side Stable Type

Rated voltage	12 VDC	24 VDC	100 VDC
Rated current	66.7 mA	33.3 mA	8 mA
Coil resistance	180 Ω	720 Ω	12,500 Ω
Coil inductance (H) (ref. value)	Armature OFF	0.93	3.7
	Armature ON	1.65	6.4
Must operate voltage	80% max. of rated voltage		
Must release voltage	10% min. of rated voltage		
Max. voltage	130% of rated voltage (at 23°C)		
Power consumption	Approx. 800 mW		

Note: 1. The rated current and coil resistance are measured at a coil temperature of 23°C with a tolerance of ±15%.
2. Operating characteristics are measured at a coil temperature of 23°C.

■ Contact Ratings

Item	SPST-NO		DPST-NO	
	Resistive load ($\cos\phi = 1$)	Inductive load ($\cos\phi = 0.4$; L/R = 7 ms)	Resistive load ($\cos\phi = 1$)	Inductive load ($\cos\phi = 0.4$; L/R = 7 ms)
Rated load	15 A at 250 VAC; 15 A at 24 VDC	10 A at 250 VAC; 7.5 A at 24 VDC	10 A at 250 VAC; 10 A at 24 VDC	7.5 A at 250 VAC; 5 A at 24 VDC
Contact material	Ag Alloy			
Rated carry current	15 A		10 A	
Max. switching voltage	250 VAC, 125 VDC			
Max. switching current	15 A		10 A	
Max. switching power	3,750 VA, 375 W	2,500 VA, 255 W	2,500 VA, 240 W	1,850 VA, 120 W
Failure rate (reference value)	100 mA at 5 VDC			

Note: P level: $\lambda_{60} = 0.1 \times 10^{-6}$ operations

■ Characteristics

Contact resistance	30 mΩ max.
Operate time	20 ms max. (mean value: approx. 13 ms)
Release time	5 ms max. (mean value: approx. 2.5 ms)
Bounce time	Operate: approx. 3 ms
Max. operating frequency	Mechanical: 18,000 operations/hr Electrical: 1,800 operations/hr (under rated load)
Insulation resistance	100 MΩ max. (at 500 VDC)
Dielectric strength	4,000 VAC, 50/60 Hz for 1 min between coil and contacts 2,000 VAC, 50/60 Hz for 1 min between contacts of different polarities (DPST-NO) 1,500 VAC, 50/60 Hz for 1 min between contacts of same polarity
Impulse withstand voltage	10,000 V (1.2 x 50 μs) between coil and contacts
Vibration resistance	Destruction: 10 to 55 to 10 Hz, 0.75-mm single amplitude (1.5-mm double amplitude) Malfunction: 10 to 55 to 10 Hz, 0.75-mm single amplitude (1.5-mm double amplitude)
Shock resistance	Destruction: 1,000 m/s ² Malfunction: 150 m/s ²
Endurance	Mechanical: 5,000,000 operations min. (at 18,000 operations/hr) Electrical: 100,000 operations min. (at 1,800 operations/hr)
Ambient temperature	Operating: -25°C to 55°C (with no icing)
Ambient humidity	Operating: 5% to 85% RH
Weight	Approx. 29 g

■ Approved Standards

UL508 (File No. E41643)/CSA C22.2 No.14 (File No.LR31928)

Model	Contact form	Coil ratings	Contact ratings
G4W-1112P-US-TV8	SPST-NO	6 to 120 VDC	15 A, 250 VAC (general use) 15 A, 24 VDC TV-8 1/2 hp, 125 VAC 1 hp, 250 VAC 3/4 hp, 240 VAC
G4W-2212P-US-TV5	DPST-NO		15 A, 250 VAC (general use) 10 A, 250 VAC (general use) 15 A, 24 VDC TV-5 1/2 hp, 250 VAC 1/3 hp, 125/250 VAC

SEMKO (File No. 204772)

Contact form	Coil ratings	Contact ratings
SPST-NO	6-100 VDC	15/120 A, 250 VAC
DPST	6-120 VDC	10/80 A, 250 VAC

VDE0435 (File No.1907)

Contact form	Coil ratings	Contact ratings
SPST-NO	6, 12, 24, 48, 100 VDC	15 A, 250 VAC ($\cos\phi = 1.0$) 10 A, 250 VAC ($\cos\phi = 0.4$) 15 A, 24 VDC (0 ms) 7.5 A, 24 VDC (40 ms)
DPST-NO		10 A, 250 VAC ($\cos\phi = 1.0$) 7.5 A, 250 VAC ($\cos\phi = 0.4$) 10 A, 24 VDC (0 ms) 5 A, 24 VDC (40 ms)

Engineering Data

Maximum Switching Power G4W-1112P-US-TV8

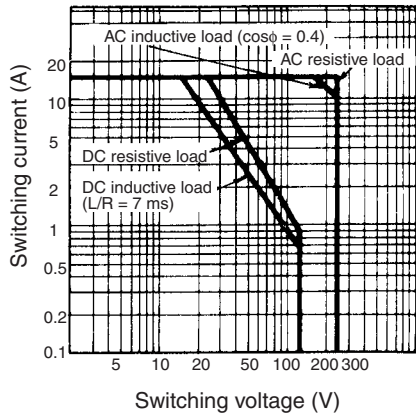

G4W-2212P-US-TV5

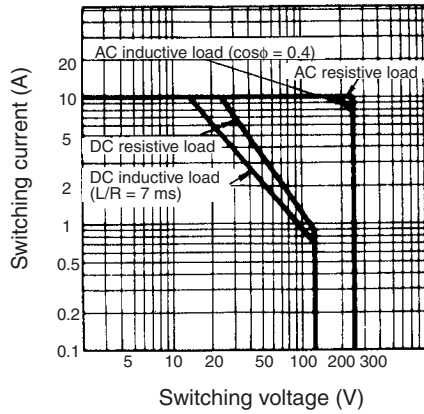

Endurance G4W-1112P-US-TV8

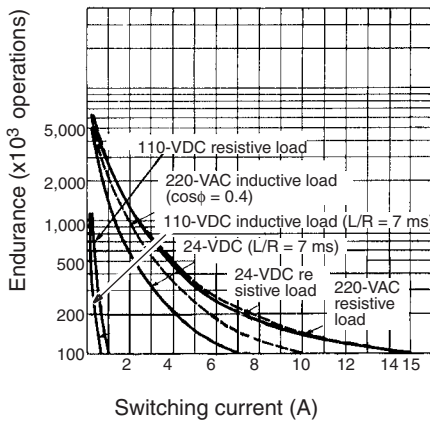

G4W-2212P-US-TV5

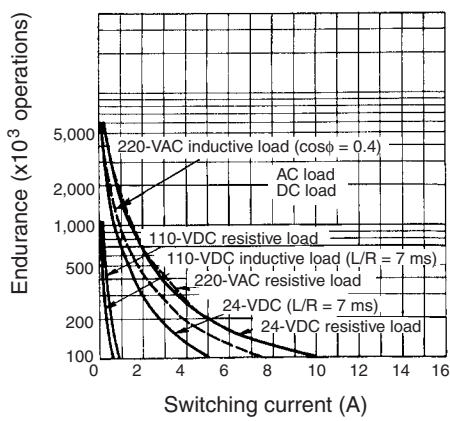

Ambient Temperature vs. Maximum Coil Voltage

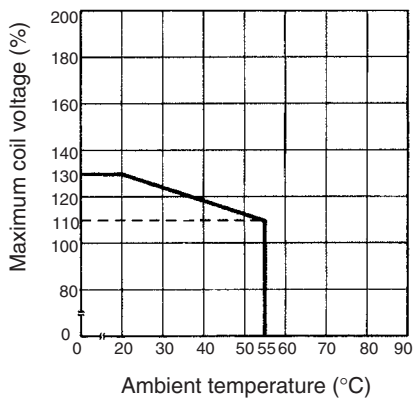

Note: The maximum coil voltage refers to the maximum value in a varying range of operating power voltage, not a continuous voltage.

Dimensions

Note: All units are in millimeters unless otherwise indicated.

G4W-□12P-US-TV

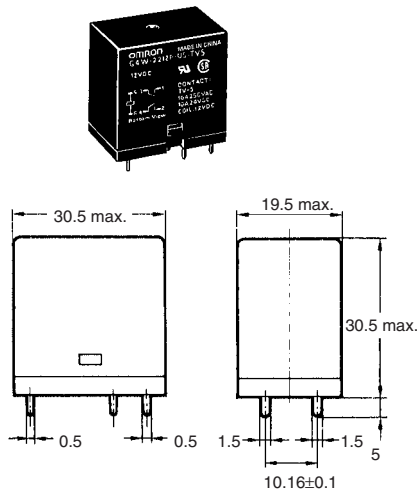

Mounting Holes (Bottom View) G4W-1112P-US-TV-8

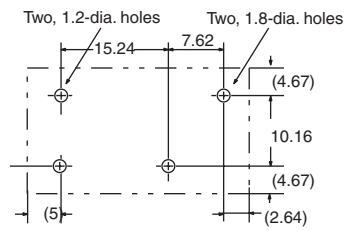

Terminal Arrangement/Internal Connections (Bottom View)

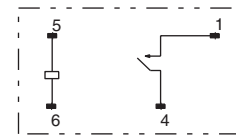

G4W-2212P-US-TV-5

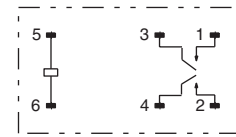
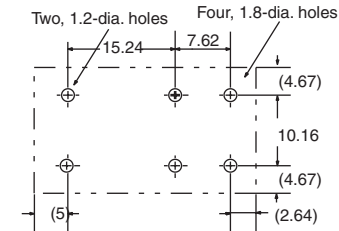

ALL DIMENSIONS SHOWN ARE IN MILLIMETERS.

To convert millimeters into inches, multiply by 0.03937. To convert grams into ounces, multiply by 0.03527.